

AIR PREPARATION UNITS

AIR FILTER series



Air Filter details :

Features :

- Suitable for modular mountings.
- Press type manual drain for easy operation.
- Bronze / Plastic sintered element .
- Separator & shield for efficient moisture separation.



Precautions :

- Note the direction of flow before installation & connect pipe accordingly.
- Nipples of taper threads to be used with teflon tape. Ensure teflon tape does not enter the unit during tightening. Nipples of straight threads to be used with sealing washer.
- Flush piping for dirt, dust, rust & other foreign particles.
- Install in clean atmosphere.
- Polycarbonate bowl may get damaged & possibly fail if exposed to synthetic oils, thinner, solvents, trichloroethylene, kerosene or other aromatic hydrocarbons.

Technical Specifications:

Model	AF-2014
Medium	Compressed air
Port Size	G1/4 BSP (F)
Bowl capacity (ml)	15
Flow rate (Ltr / Min)	800
Maximum supply pressure (bar)	10
Filtration (µm)	1, 5, 25, 40 (standard) , 50,100
Bowl material	Polycarbonate
Ambient / Medium temperature	5° - 60° C
Installation	Vertical (As in the picture)
Materials of construction	Aluminium, Brass, Steel, SS, Nitrile
Optional accessories	Clamp, Modular mounting kit, Pr. gauge
Weight (Kg)	0.182

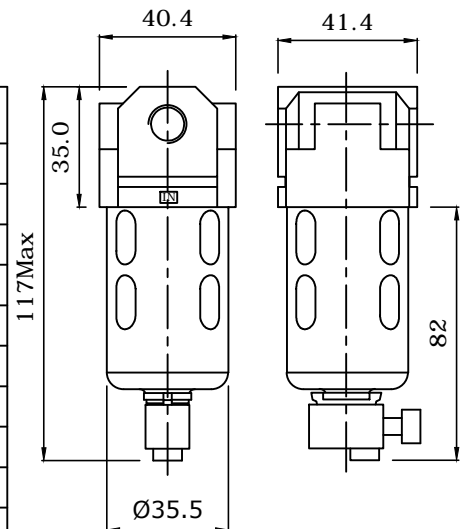

- Supply pressure 6 bar , pressure drop $p= 0.3$ bar (for standard models).



Manufactured by :

Kushako India

Office : 490, Narayan Peth, Opp. Pune Marathi Granthalaya, Pune - 411030. (Maharashtra), Website : www.kushakoindia.com

Works : Sr.No. 25/1A, Village Nanded, Sinhgad Road, Tal - Haveli, Dist. Pune -411041

Tel. No : 901169077 / 7620674777

E-mail : kushako.india@gmail.com / kushakoindia1992@gmail.com